

Section <b>09</b>	Applicable Model/s <b>1999 Miata</b>	Subject <b>SOFT TOP COVER COMES OFF OR BREAKS</b>	Bulletin No. <b>007/99R</b>
			Issued <b>05/21/99</b>
			Revised <b>06/04/99</b>

### BULLETIN REVISION NOTE

- The PART(S) INFORMATION section of this bulletin has been revised.

### APPLICABLE MODEL(S)/VINS

All 1999 Miatas with VINs lower than JM1 NB353\* X0 119960.

### DESCRIPTION

The soft top cover may exhibit the following conditions:

- A. Soft top may tear when trying to remove it due to fasteners connecting too tightly.
- B. Soft top cover cloth gradually comes apart at the seams due to wind pressure.
- C. Soft top cover fastener(s) may fly off from wind pressure while driving.

A modified part is available which has been reinforced, stitched at the seams, and shorten for a tighter fit.

Customers having this concern should have their vehicle repaired using the following procedure.

### REPAIR PROCEDURE

- Verify customer concern.
- Replace soft top cover with modified part.
- Verify repair.

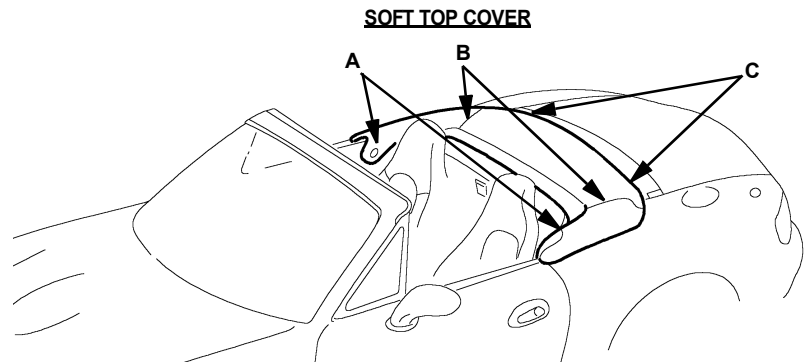

### PART(S) INFORMATION

Part Number	Description	Qty.	Notes
NC10 R1 960C 66	Soft top cover	1	Black
NC10 R1 960C 21	Soft top cover	1	Tan
NC10 R1 960C 53	Soft top cover	1	Blue

### WARRANTY INFORMATION

#### Note

- This information applies to verified customer complaints on vehicles covered under normal warranty. Refer to the SRT microfiche for warranty term information.

Warranty Type	A
Symptom Code	92

**CONSUMER NOTICE:** The information and instructions in this bulletin are intended for use by skilled technicians. Mazda technicians utilize the proper tools / equipment and take training to correctly and safely maintain Mazda vehicles. These instructions should not be performed by "do-it-yourselfers." Consumers should not assume this bulletin applies to their vehicle or that their vehicle will develop the described concern. To determine if the information applies, consumers should contact their nearest authorized Mazda dealership.

<b>Number: 09 - 007/99R</b>	<b>Date Issued: 05/21/99</b>	<b>Revised: 06/04/99</b>
-----------------------------	------------------------------	--------------------------

Damage Code	9A
Part Number Main Cause	NC10 R1 960C
Quantity	1
Operation Number / Labor Hours	S2109XRX / 0.2